

# Singer 17-33

Form 19184  
(538)  
Printed in U. S. A.

# LIST OF PARTS



MACHINE No. 17-33

---

THE SINGER MANUFACTURING COMPANY

## INSTRUCTIONS FOR OILING

To ensure easy running and prevent unnecessary wear of the parts which are in movable contact, the machine requires oiling and when in continuous use, it should be oiled at least twice each day with Singer Manufacturing Sewing Machine Oil (Cloth and Leather).

Copyright, U. S. A., 1937 and 1938  
by The Singer Manufacturing Co.  
All Rights Reserved for all Countries

## INDEX

	Page
Accessories.....	9
Bobbin Winder.....	9
Cloth Plate.....	10
Machine Base.....	10
Machine No. 17-33.....	5
Numerical List of Parts.....	21
Work Guiding Sleeve.....	20

From the library of: Diamond Needle Corp.

## INSTRUCTIONS FOR ORDERING

In ordering from this list, use ONLY the part NUMBER in the FIRST column.

The number stamped on a Sewing Machine Part is in every case the number of the single part only.

Every combination of parts sent out as such has its specific number, which, although not stamped on the parts, must be used when ordering the combination.

Each number always indicates the SAME PART in whatever list it appears, or for whatever machine.

The letters after some of the numbers indicate the style of finish only, as follows:

- A-Hardened, Polished, Nickel Plated and Buffed
- B-Polished, Nickel Plated and Buffed
- C-Hardened Only
- D-Polished Only
- E-Soft, Not Polished
- F-Hardened and Polished
- F.J-Hardened, Polished and Nickel Plated
- G-Bright Rumbled and Nickel Plated
- H-Blued
- J-Nickel Plated Only
- K-Hardened and Nickel Plated
- L-Brass Plated
- M-Oxidized
- N-Japanned, Dull
- P-Japanned, Bright
- R-Merlized
- S-Cadmium Plating
- T-Copper Plated
- T.A-Hardened, Polished, Copper and Nickel Plated and Buffed
- T.B-Copper and Nickel Plated and Polished
- T.J-Copper and Nickel Plated Only
- T.K-Hardened, Copper and Nickel Plated
- T.L-Copper and Brass Plated
- T.M-Copper Plated and Oxidized
- U-Zinc Plated
- V-Silver Plated
- W-Polished and Nickel Plated
- X-Black Oxide, for Iron and Steel
- X.C-Hardened and Black Oxide, for Iron or Steel
- Y-Black Nickel Plated Only
- Z-Chromium Plated
- Z.A-Hardened, Polished, Nickel Plated, Buffed and Chromium Plated
- Z.B-Polished, Nickel Plated, Buffed and Chromium Plated
- Z.C-Hardened and Chromium Plated
- Z.J-Nickel and Chromium Plated

These letters MUST BE USED when they appear in the list; and AFTER the number as in the list.

In this series:

- 1 to 1500, 50001 to 51500 and 140001 to 142000 are Screw Numbers
- 1501 to 1800 and 51501 to 51800 are Nut Numbers
- 1801 to 2000 and 51801 to 52000 are Roller Numbers
- 2001 to 50000 and 52001 to 140000 and 142001 to 190000 are Sewing Machine Parts, 190001 and upward are numbers of Electrical Parts.

The figures in the second column refer only to the plates, illustrating the parts, and are NOT TO BE USED in ordering.

Parts marked with an asterisk (\*) are furnished only when repairs are made at factory.

# Counter Copy

## LIST OF PARTS COMPLETE FOR

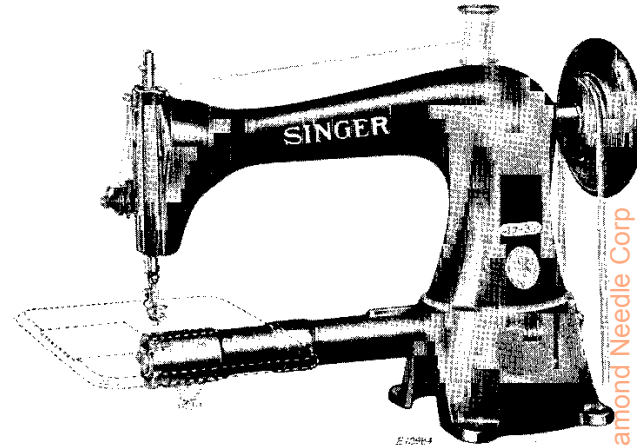

MACHINE No. 17-33

For Darning Table Linen, Towels, Knit Underwear, etc.  
No feeding mechanism. Presser bar rises automatically after each stitch is made. A counterbalanced arm shaft reduces vibration to a minimum when driven by power. Speed 1400 R. P. M.

No.	Plate	Name
*65132	-----	Arm with 4448, 15404, 16717 and two 15405.....
4389	20924	Arm Dowel Pin.....
4448	20923	" Oil Tube for oiling intermediate bearing.....
	123E 20924	Arm Screw.....
65106	20923	" Shaft.....
65133	-----	" " 65106 with 65107 and 65139....
3005	20923	" " Bushing (back).....
448C	20923	" " " Set Screw.....
*16717	20923	" " " (front).....
65107	20923	" " Counterbalance with 1362C....
1362C	20923	" " " Position Screw.....
144D	20923	" " Screw.....
4288	20923	" Side Cover.....

From the library of: Diamond Needle Corp

## PARTS FOR MACHINE No. 17-33

No.	Plate	Name
51224D	20923	Arm Side Cover Thumb Screw.....
52239	20923	" Spool Pin and Thread Eyelet.....
8879	20923	" " " Washer (cloth).....
16267	20923	Balance Wheel (disc) power, 2 3/4 in. pulley, with two 448C.....
16278	20923	Balance Wheel (disc) stand, 3 in. pulley, for clamp stop motion.....
448C	20923	Balance Wheel Set Screw.....
256J	20923	Clamp Stop Motion Clamp Screw.....
248A	20923	" " " " Stop Screw.....
2020	20923	" " " " Washer.....
*3023	-----	" " " " Flanged Bushing.....
4933	20923	" " " " " " 3023 with two 462C.....
2022	-----	Clamp Stop Motion Flanged Bushing Pin..
462C	20923	" " " " " " Set Screw.....
3022	-----	Clamp Stop Motion complete, Nos. 248A, 256J, 2020 and 4933.....
4292	20923	Crank Connecting Rod with two 145E.....
145E	20923	" " " " Cap Screw.....
375C	20923	" " " " Hinge Screw.....
1518J	20923	" " " " " " Nut...
*65108	-----	Cylinder, 1 7/8 in. diam.....
16723	20925	Face Plate.....
16881	-----	" " 16723 with 2105.....
16883	20925	Face Plate complete, Nos. 448C, 460C, 2107, 2127, 12296, 16881, 16882 and two 233J
164J	20925	Face Plate Screw.....
2107	20925	" " Thread Guard (lower).....
233J	20925	" " " " " " Screw..
12296	20925	" " " " " " (upper).....
460C	20925	" " " " " " Set Screw
65109	20926	Needle Bar (hollow).....
*3045	20926	" " Connecting Link.....
65134	-----	" " " " " " 3045 with 65135.....
377C	20926	Needle Bar Connecting Link Hinge Screw.
1518J	20926	" " " " " " " " Nut.....
65135	20926	Needle Bar Connecting Stud with 175E...
175E	20926	" " " " " " Clamping Screw.....
290E	20926	Needle Bar Screw Bushing.....
16725	20926	" " Thread Eyelet.....
662J	20926	" " " " " " Screw.....
1678C	20926	" Clamping Nut.....
16726	-----	" Plate, large needle hole.....
16727	20925	" " small needle hole.....

## PARTS FOR MACHINE No. 17-33

No.	Plate	Name
1231D	20925	Needle Plate Screw.....
*6022	-----	Oscillating Rock Shaft with 4784.....
16806	20923	" " " " 6022 with 65131.
65130	20923	" " " " Hinge Pin.....
65131	-----	" " " " " " 65130 with 1513J.....
1513J	20923	Oscillating Rock Shaft Hinge Pin Nut...
4784	20923	" " " " Oil Pad (felt)..
6462	20923	" Shaft.....
*16835	-----	" " 6462 with 2049, 7225 and 16736.....
*7225	-----	Oscillating Shaft Crank with 219C and 1813.....
7054	20923	Oscillating Shaft Crank with 1813 and two 462C.....
2049	-----	Oscillating Shaft Crank Pin.....
1813	20923	" " " " Roller and Stud
219C	-----	" " " " Set Screw for 7225.....
462C	20923	Oscillating Shaft Crank Set Screw for 7054.....
8224	20926	Presser Bar.....
65136	20926	" " Guide Bracket with 454C..
65141	-----	" " " " " " 65136 with 16733 and 50022C.....
454C	20926	Presser Bar Guide Bracket Set Screw..
52016	20926	" " Lifter.....
689C	20926	" " " " Screw.....
1520J	20926	" " " " " " Nut.....
16730	20926	" " Lifting Rock Shaft.....
65137	20926	" " " " " " Arm with 172C and 1979.....
172C	20926	Presser Bar Lifting Rock Shaft Arm Clamping Screw.....
1979	20926	Presser Bar Lifting Rock Shaft Arm Roller and Screw Stud.....
65138	20926	Presser Bar Lifting Rock Shaft Arm Spring.....
16733	20926	Presser Bar Lifting Rock Shaft Link....
810D	20926	" " " " " " " " Cap Screw.....
50022C	20926	Presser Bar Lifting Rock Shaft Link Hinge Screw.....
290E	20926	Presser Bar Screw Bushing.....
3100	20926	" " Spring.....
2070	20926	" " " " Washer.....
*65037	-----	" Foot.....
65038	-----	" " Finger Guard.....
65039	20926	Presser Foot with Finger Guard complete, Nos. 65037 and 65038.....

## PARTS FOR MACHINE No. 17-33

No.	Plate	Name
190J	20926	Presser Foot Screw.....
262J	20926	Pressure Regulating Thumb Screw.....
2996	20925	Shuttle Bobbin.....
15140	20925	" " Case Latch.....
2973	20925	" " " " Lever.....
2974	20925	" " " " Fulcrum Pin.....
2975	20925	Shuttle Bobbin Case Latch Spring.....
592E	20925	" " " " Stop Screw....
15141	-----	" " " Hinge, Nos. 2973, 2974 and 15140.....
*39623	-----	Shuttle Bobbin Case Position Finger....
2523	-----	" " " " Rivet
40112	20925	Shuttle Bobbin Case complete, Nos. 591F, 592E, 2523, 2975, 15141, 15278 and 39623.....
16614	20925	Shuttle Body.....
591F	20925	" Tension Regulating Screw.....
15278	20925	" " Spring.....
16735	20925	" 1 1/2 in. diam., Nos. 2996, 16614 and 40112.....
16736	20923	Shuttle Driver.....
2049	20923	" " Pin.....
16838	20925	" Race.....
16738	20925	" " Cover.....
979D	20925	" " " Hinge Screw.....
50258J	20925	" " Screw.....
2102	20925	Tension Disc.....
1560C	20925	" Regulating Thumb Nut.....
600C	20925	" Screw Stud.....
16202	-----	" " " 600C with 1560C.....
448C	20925	" " " Set Screw.....
10148	20925	" Spring.....
2105	20925	" Thread Guard.....
16882	20925	Tension complete, Nos. 10148, 16202, 16766 and two 2102.....
*65139	-----	Thread Take-up Cam.....
65140	20923	" " " 65139 with 448C.....
3012	20923	" " " Pin.....
446C	20923	" " " Set Screw.....
*16740	20923	" " Lever with 1819.....
65034	-----	" " " 16740 with 1088C..
1088C	20923	" " " Hinge Screw.....
889C	20923	" " " " Set Screw.....
1819	20923	Thread Take-up Lever Roller and Stud...
16766	20925	" " Spring.....
2127	20925	" " " Regulator Plate..
233J	20925	" " " " Ad- justing Screw.....
6053	20927	Drip Pan.....
*15404	-----	Trade Mark.....
15405	-----	" " Rivet.....

## ACCESSORIES

No.	Plate	Name
51072E	20927	Machine Bolt with 51581E, to secure ma- chine to table.....
51581E	20927	Machine Bolt Nut.....
6055	20927	" " " Washer.....
120342	20927	Oiler (copper plated) with 120343.....
120343	20927	" Spout, 3 1/2 in. long.....
26026	20927	Screw Driver (machine).....
26485	20927	" " (shuttle tension).....
8908	20927	Wrench for 1520.....
4347	20927	" " 1513 and 1518.....
19079	20927	" " 1678.....

## BOBBIN WINDER

(SWINGING AUTOMATIC, RIGHT HAND)

No.	Plate	Name
27540	20928	Base.....
15072	20928	Bobbin Position Pin.....
27302	20928	Frame.....
50356D	20928	" Hinge Screw.....
1620J	20928	" " " Nut.....
27303	20928	" Spring.....
27541	20928	Pulley.....
*27849	20928	Spindle.....
-----	-----	" 27849 with 15072, 27850 and 41828
*27850	20928	" Collar.....
41828	20928	" " Pin.....
27306	20928	Spool Pin.....
150534	20928	" Stand.....
150535	20928	Spool Stand complete, Nos. 418E, 1562J, 2106, 10141, 11241, 27306, 150534 and two each 2455 and wood screws 1 in. No. 10.....
11241	20928	Spool Washer (cloth).....
27312	20928	Stop Latch.....
35D	20928	" " Hinge Screw.....
2455	20928	Tension Disc.....
1562J	20928	" Regulating Thumb Nut.....
418E	20928	" Screw Stud.....
10141	20928	" Spring.....
2106	20928	" Thread Guide.....

From the library of: Diamond Needle Corp.

## BOBBIN WINDER

No.	Plate	Name
27647	20928	Bobbin Winder, Nos. 35D, 1620J, 27302, 27303, 27312, 27538, 27540, 27541, 50356D and two wood screws 1 in.No. 7.....
150536	20928	Bobbin Winder (swinging automatic, right hand) complete, Nos. 27647 and 150536

## CLOTH PLATE

No.	Plate	Name
16718	20924	Cloth Plate.....
16719	20924	" " Bracket with 345C.....
345C	20924	" " " Set Screw.....
389F	20924	" " " Screw.....
16695	20924	" " Slide.....
3286	20924	" " " Spring.....
725J	20924	" " " Screw.....
16720	20924	Cloth Plate complete, Nos. 3286, 16695, 16718 and two 725J.....
16721	20924	Cloth Plate with Bracket complete, Nos. 16719, 16720 and two 389F.....

## MACHINE BASE

No.	Plate	Name
7169	20927	Machine Base with four each 6055, 51070E and wood screws 1 in. No. 12.....
51070E	20927	Machine Bolt with 51581E, to secure machine to base.....
51581E	20927	Machine Bolt Nut.....
6055	20927	" " " Washer.....

## WORK GUIDING SLEEVE

No.	Plate	Name
121166	20924	Work Guiding Sleeve with 50379C.....
50379C	20924	" " " Stop Screw.....

## NUMERICAL LIST OF PARTS

No.	Plate	Name
35D	20928	Bobbin Winder Stop Latch Hinge Screw for 27647.....
123E	20924	Arm Screw.....
144D	20923	" Shaft Screw.....
145E	20923	Crank Connecting Rod Cap Screw for 4292
164J	20925	Face Plate Screw.....
172C	20926	Presser Bar Lifting Rock Shaft Arm Clamping Screw for 65137.....
175E	20926	Needle Bar Connecting Stud Clamping Screw for 65135.....
190J	20926	Presser Foot Screw.....
219C	-----	Oscillating Shaft Crank Set Screw for 7225.....
233J	20925	Face Plate Thread Guard (lower) Screw for 16883.....
233J	20925	Thread Take-up Spring Regulator Plate Adjusting Screw for 16883.....
248A	20923	Clamp Stop Motion Clamp Stop Screw for 3022.....
256J	20923	Clamp Stop Motion Clamp Screw for 3022
262J	20926	Pressure Regulating Thumb Screw.....
290E	20926	Needle Bar Screw Bushing.....
290E	20926	Presser Bar Screw Bushing.....
345C	20924	Cloth Plate Bracket Set Screw for 16719
375C	20923	Crank Connecting Rod Hinge Screw.....
377C	20926	Needle Bar Connecting Link Hinge Screw
369F	20924	Cloth Plate Bracket Screw for 16721.....
418E	20928	Bobbin Winder Tension Screw Stud for 150535.....
446C	20923	Thread Take-up Cam Set Screw for 65140
448C	20923	Arm Shaft Bushing (back) Set Screw.....
448C	20923	Balance Wheel Set Screw for 16267.....
448C	20925	Tension Screw Stud Set Screw for 16883
454C	20926	Presser Bar Guide Bracket Set Screw for 65136.....
460C	20925	Face Plate Thread Guard (upper) Set Screw for 16883.....
462C	20923	Clamp Stop Motion Flanged Bushing Set Screw for 4933.....
462C	20923	Oscillating Shaft Crank Set Screw for 7054.....
591F	20925	Shuttle Tension Regulating Screw for 40112.....
592E	20925	Shuttle Bobbin Case Latch Stop Screw for 40112.....
600C	20925	Tension Screw Stud for 16202.....
662J	20926	Needle Bar Thread Eyelet Screw.....
689C	20926	Presser Bar Lifter Screw.....
725J	20924	Cloth Plate Slide Spring Screw for 16720.....

## NUMERICAL LIST OF PARTS

No.	Plate	Name
810D	20926	Presser Bar Lifting Rock Shaft Link Cap Screw.....
889C	20923	Thread Take-up Lever Hinge Screw Set Screw.....
979D	20925	Shuttle Race Cover Hinge Screw.....
1088C	20923	Thread Take-up Lever Hinge Screw for 65034.....
1231D	20925	Needle Plate Screw.....
1362C	20923	Arm Shaft Counterbalance Position Screw for 65107.....
1513J	20923	Oscillating Rock Shaft Hinge Pin Nut for 65131.....
1518J	20923	Crank Connecting Rod Hinge Screw Nut...
1518J	20926	Needle Bar Connecting Link Hinge Screw Nut.....
1520J	20926	Presser Bar Lifter Screw Nut.....
1560C	20925	Tension Regulating Thumb Nut for 16202..
1562J	20928	Bobbin Winder Tension Regulating Thumb Nut for 150535.....
1620J	20928	Bobbin Winder Frame Hinge Screw Nut for 27647.....
1678C	20926	Needle Clamping Nut.....
1813	20923	Oscillating Shaft Crank Roller and Stud for 7054 and 7225.....
1819	20923	Thread Take-up Lever Roller and Stud for 16740.....
1979	20926	Presser Bar Lifting Rock Shaft Arm Roller and Screw Stud for 65137....
2020	20923	Clamp Stop Motion Clamp Washer for 3022
2022	----	" " Flanged Bushing Pin..
2049	----	Oscillating Shaft Crank Pin.....
2049	20923	Shuttle Driver Pin for 16835.....
2070	20926	Presser Bar Spring Washer.....
2102	20925	Tension Disc for 16882.....
2105	20925	" Thread Guard for 16881.....
2106	20928	Bobbin Winder Tension Thread Guide for 150535.....
2107	20925	Face Plate Thread Guard (lower) for 16883.....
2127	20925	Thread Take-up Spring Regulator Plate for 16883.....
2455	20928	Bobbin Winder Tension Disc for 150535..
2523	----	Shuttle Bobbin Case Position Finger Rivet for 40112.....
2973	20925	Shuttle Bobbin Case Latch Lever for 15141.....
2974	20925	Shuttle Bobbin Case Latch Lever Fulcrum Pin for 15141.....
2975	20925	Shuttle Bobbin Case Latch Spring for 40112.....

## NUMERICAL LIST OF PARTS

No.	Plate	Name
2996	20925	Shuttle Bobbin for 16735.....
3005	20923	Arm Shaft Bushing (back).....
3012	20923	Thread Take-up Cam Pin.....
3022	----	Clamp Stop Motion complete, Nos. 248A, 256J, 2020 and 4933.....
*3023	----	Clamp Stop Motion Flanged Bushing for 4933.....
*3045	20926	Needle Bar Connecting Link for 65134...
3100	20926	Presser Bar Spring.....
3286	20924	Cloth Plate Slide Spring for 16720.....
4288	20923	Arm Side Cover.....
4292	20923	Crank Connecting Rod with two 145E.....
4347	20927	Wrench for 1513 and 1518 (Accessories)
4369	20924	Arm Dowel Pin.....
4448	20923	" Oil Tube for oiling intermediate bearing for 65132.....
4784	20923	Oscillating Rock Shaft Oil Pad (felt) for 6022.....
4933	20923	Clamp Stop Motion Flanged Bushing 3023 with two 462C for 3022.....
*6022	----	Oscillating Rock Shaft with 4784 for 16806.....
6053	20927	Drip Pan.....
6055	20927	Machine Bolt Nut Washer for 7169.....
6055	20927	" " " " (Accessories)...
6462	20923	Oscillating Shaft for 16835.....
7054	20923	" " Crank with 1813 and two 462C.....
7169	20927	Machine Base with four each 6055, 51070E and wood screws 1 in. No. 12.....
*7225	----	Oscillating Shaft Crank with 219C and 1813 for 16835.....
8224	20926	Presser Bar.....
8879	20923	Arm Spool Pin Washer (cloth).....
8908	20927	Wrench for 1520 (Accessories).....
10141	20928	Bobbin Winder Tension Spring for 150535
10148	20925	Tension Spring for 16882.....
11241	20928	Bobbin Winder Spool Washer (cloth) for 150535.....
12296	20925	Face Plate Thread Guard (upper) for 16883.....
15072	20928	Bobbin Winder Bobbin Position Pin for 27538.....
15140	20925	Shuttle Bobbin Case Latch for 15141....
15141	----	Shuttle Bobbin Case Hinge, Nos. 2973, 2974 and 15140 for 40112.....
15278	20925	Shuttle Tension Spring for 40112.....
*15404	----	Trade Mark for 65132.....
15405	----	" " Rivet for 65132.....



## NUMERICAL LIST OF PARTS

No.	Plate	Name
16202	-----	Tension Screw Stud 600C with 1560C for 16882.....
16267	20923	Balance Wheel (disc) power, 2 3/4 in. pulley, with two 448C.....
16278	20923	Balance Wheel (disc) stand, 3 in. pulley, for clamp stop motion.....
16614	20925	Shuttle Body for 16735.....
16695	20924	Cloth Plate Slide for 16720.....
*16717	20923	Arm Shaft Bushing (front) for 65132....
16718	20924	Cloth Plate for 16720.....
16719	20924	" " Bracket with 345C for 16721
16720	20924	Cloth Plate complete for 16721, Nos. 3286, 16695, 16718 and two 725J....
16721	20924	Cloth Plate with Bracket complete, Nos. 16719, 16720 and two 389F.....
16723	20925	Face Plate for 16881.....
16725	20926	Needle Bar Thread Eyelet.....
16726	-----	" Plate, large needle hole.....
16727	20925	" " small needle hole.....
16730	20926	Presser Bar Lifting Rock Shaft.....
16733	20926	" " " " Link for 65141.....
16735	20925	Shuttle 1 1/2 in. diam., Nos. 2996, 16614 and 40112.....
16736	20923	Shuttle Driver for 16835.....
16738	20925	" Race Cover.....
*16740	20923	Thread Take-up Lever with 1819 for 65034.....
16766	20925	Thread Take-up Spring for 16882.....
16806	20923	Oscillating Rock Shaft 6022 with 65131.
*16835	-----	" Shaft 6462 with 2049, 7225 and 16736.....
16838	20925	Shuttle Race.....
16881	-----	Face Plate 16723 with 2105 for 16883...
16882	20925	Tension complete for 16883, Nos. 10148, 16202, 16766 and two 2102.....
16883	20925	Face Plate complete, Nos. 448C, 460C, 2107, 2127, 12296, 16881, 16882 and two 233J
19079	20927	Wrench for 1678 (Accessories).....
26026	20927	Screw Driver (machine) Accessories....
26485	20927	" " (shuttle tension) Accessories.....
27302	20928	Bobbin Winder Frame for 27647.....
27303	20928	" " Spring for 27647....
27306	20928	" " Spool Pin for 150535.....
27312	20928	" " Stop Latch for 27647.....
27538	-----	" Spindle 27849 with 15072, 27850 and 41828 for 27647.....
27540	20928	Bobbin Winder Base for 27647.....

## NUMERICAL LIST OF PARTS

No.	Plate	Name
27541	20928	Bobbin Winder Pulley for 27647.....
27647	20928	Bobbin Winder, Nos. 35D, 1620J, 27302, 27303, 27312, 27538, 27540, 27541, 50356D and two wood screws 1 in. No. 7 for 150536.....
*27849	20928	Bobbin Winder Spindle for 27538.....
*27850	20928	" " Collar for 27538.
*39623	-----	Shuttle Bobbin Case Position Finger for 40112.....
40112	20925	Shuttle Bobbin Case complete for 16735, Nos. 591F, 592E, 2523, 2975, 15141, 15278 and 39623.....
41828	20928	Bobbin Winder Spindle Collar Pin for 27538.....
50022C	20926	Presser Bar Lifting Rock Shaft Link Hinge Screw for 65141.....
50258J	20925	Shuttle Race Screw.....
50356D	20928	Bobbin Winder Frame Hinge Screw for 27647.....
50379C	20924	Work Guiding Sleeve Stop Screw for 121166.....
51070E	20927	Machine Bolt with 51581E, to secure machine to base for 7169.....
51072E	20927	Machine Bolt with 51581E, to secure machine to table (Accessories).....
51224D	20923	Arm Side Cover Thumb Screw.....
51581E	20927	Machine Bolt Nut for 51070E and 51072E.
52016	20926	Presser Bar Lifter.....
52239	20923	Arm Spool Pin and Thread Eyelet.....
65034	-----	Thread Take-up Lever 16740 with 1086C..
*65037	-----	Presser Foot for 65039.....
65038	-----	" " Finger Guard for 65039....
65039	20926	Presser Foot with Finger Guard complete, Nos. 65037 and 65038.....
65106	20923	Arm Shaft for 65133.....
65107	20923	" " Counterbalance with 1362C for 65133.....
*65108	-----	Cylinder 1 7/8 in. diam.....
65109	20926	Needle Bar (hollow).....
65130	20923	Oscillating Rock Shaft Hinge Pin for 65131.....
65131	-----	Oscillating Rock Shaft Hinge Pin 65130 with 1513J for 16806.....
*65132	-----	Arm with 4448, 15404, 16717 and two 15405
65133	-----	" Shaft 65106 with 65107 and 65139....
65134	-----	Needle Bar Connecting Link 3045 with 65135.....
65135	20926	Needle Bar Connecting Stud with 175E for 65134.....

From the Library of Dr. Martin Luther King Jr.

## NUMERICAL LIST OF PARTS

No.	Plate	Name
65136	20926	Presser Bar Guide Bracket with 454C for 65141.....
65137	20926	Presser Bar Lifting Rock Shaft Arm with 172C and 1979.....
65138	20926	Presser Bar Lifting Rock Shaft Arm Spring.....
*65139	-----	Thread Take-up Cam for 65133 and 65140.
65140	20923	" " " 65139 with 446C.....
65141	-----	Presser Bar Guide Bracket 65136 with 16733 and 50022C.....
120342	20927	Oiler (copper plated) with 120343 (Accessories).....
120343	20927	Oiler Spout, 3 1/2 in. long for 120342.
121166	20924	Work Guiding Sleeve with 50379C.....
150534	20928	Bobbin Winder Spool Stand for 150535...
150535	20928	Bobbin Winder Spool Stand complete for 150536, Nos. 418E, 1562J, 2106, 10141, 11241, 27306, 150534 and two each 2455 and wood screws 1 in. No. 10..
150536	20928	Bobbin Winder (swinging automatic, right hand) complete, Nos. 27647 and 150535

Genuine Singer Needles should be used  
in Singer Machines.  
These Needles and their Containers  
are marked with the  
Company's Trade Mark "SIMANCO." 1

Needles in Containers marked  
"For Singer Machines"  
are not Singer made needles. 2

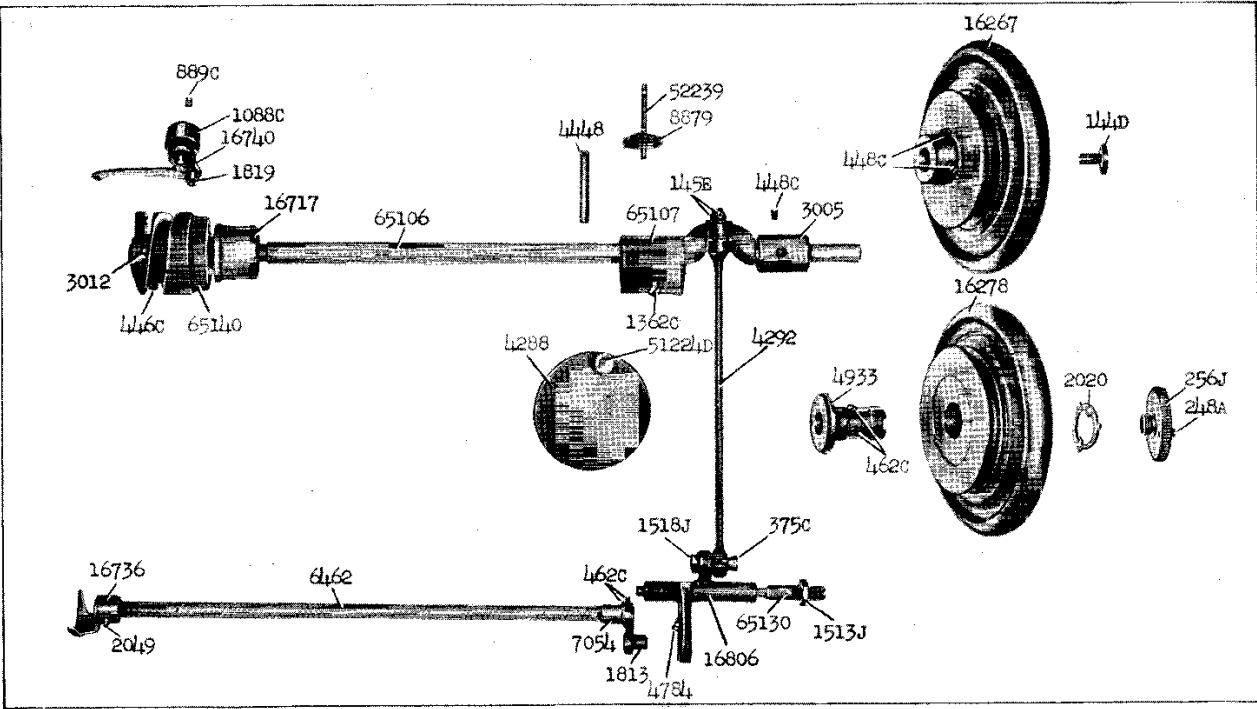

20923 - 1/4

20924 - 1/3

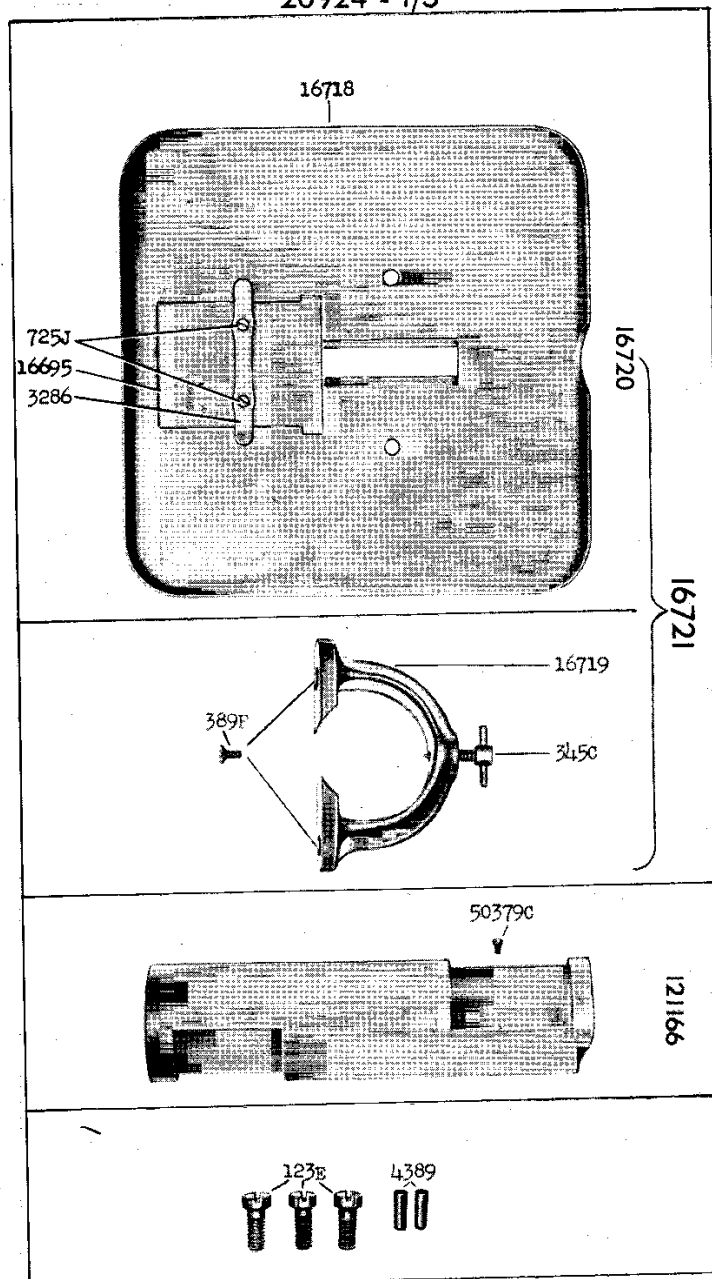

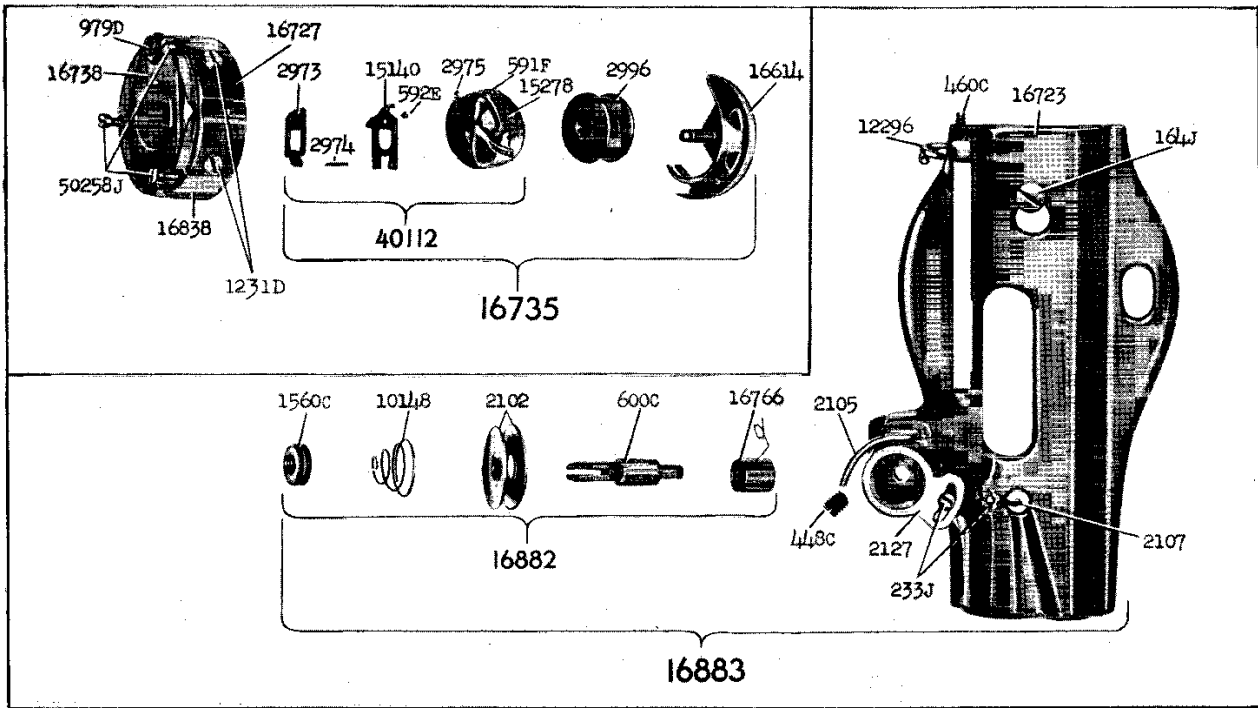

20925 - 1/2

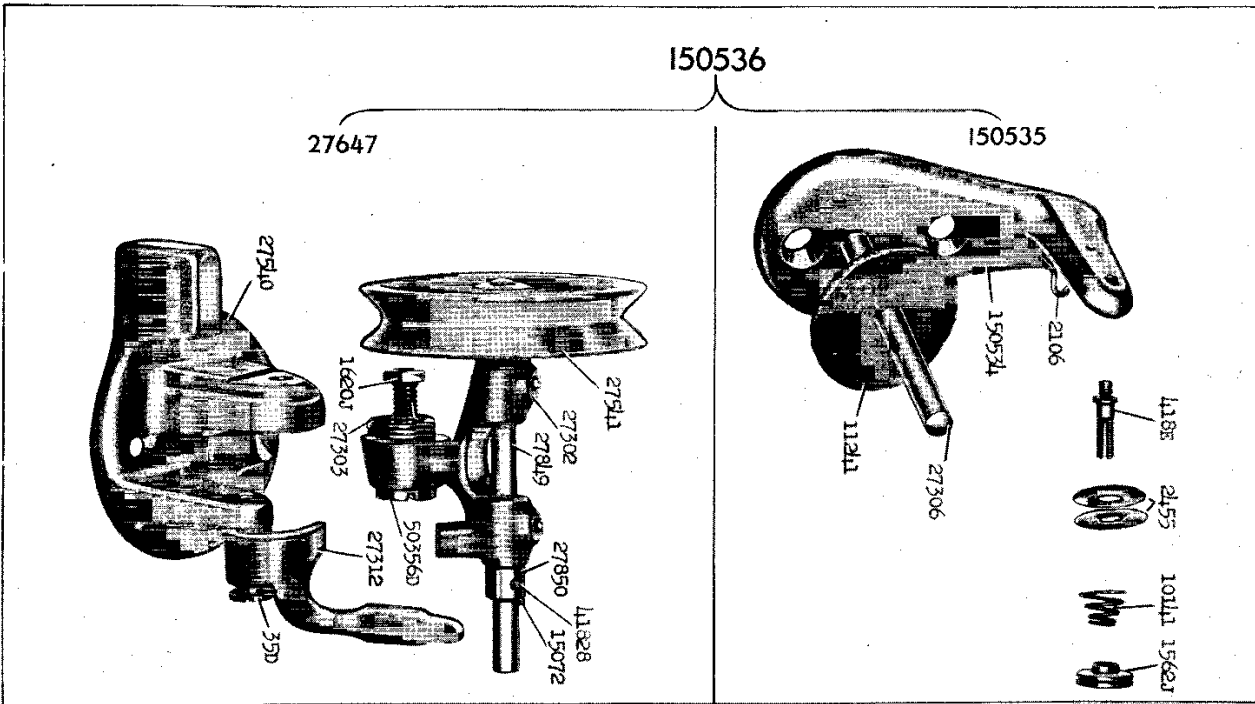

20928 - 2/3

From the library of: Diamond Needle Corp

Genuine Singer Needles should be used  
in Singer Machines.  
These Needles and their Containers  
are marked with the  
Company's Trade Mark "SIMANCO." 1

Needles in Containers marked  
"For Singer Machines"  
are not Singer made needles. 2